



Course Title: (الشبكات العصبية الاصطناعية) المقرر اختياري (1)
Date: Jan 28th 2010 (First term)

Course Code: CCE3152
Allowed time: 3 hrs

Year: 3rd (Communications)
No. of Pages: (2)

Remarks: (Attempt ALL the following problems and assume any missing data)

Problem number (1) [20 Marks]

- a) Verify that the derivative of the logistic function of an input, u , and an output, y , can be expressed in terms of its own output thus: $\frac{dy}{du} = y(1-y)$. [2 Marks]
- b) A system output was collected using a sensor according to the function $h = 5(1 - \sin(\frac{\pi}{8}t))$; $t \geq 0$, where h and t are the sensor output and the time, respectively. It is required to model the system by approximating its output to be linear in the region $0 \leq t \leq 3$. If only the first four (4) samples, with 1 Hz sampling frequency, are available, find the system model using your knowledge about the ANN. [10 Marks]
- c) Design an ANN to model the logical NOR function of two inputs. Then, implement and draw its corresponding electronic circuit and find the values of resistors if the amplitude of the power supply voltage, U_s , is 6 volts. [8 Marks]

Problem number (2) [22 Marks]

- a) Derive the learning algorithm for a **single** non-linear adaptive Perceptron that can be used for the general function approximation problem without the shortcomings of the explicit expansion technique. Suggest a suitable nonlinear activation function. What condition must this activation function hold? [10 Marks]
- b)
- I) Draw a sketch of a Biological Neuron showing its main parts,
 - II) Hence, draw the corresponding labelled artificial McCulloch-Pitts model.
 - III) What do the following terms mean? (Please give **short notes** about their functions).

i. Dendrites,	ii. Cell body,
iii. Axon,	iv. Synapse
- [8 Marks]
- c) What does it mean by local and global minima? When does this case emerge? Explain with the aid of graphs. [4 Marks]

Problem number (3)

[20 Marks]

a) For a **linear** model of an ANN, derive the algorithm to find the weights vector that minimizes the Mean-Squared-Errors (MSE) when the inputs and output vectors (measurements) are given. What condition must hold for this to be a valid solution?

[10 Marks]

b) Is it possible to model the logical Exclusive-OR function of two inputs with only one Perceptron? Why? Depending on your answer, design a two-input XOR function.

[10 Marks]

Problem number (4)

[23 Marks]

a) Draw and label a **multi-layer** Perceptron with a single hidden layer and a single output unit and **only** write down its operational (feed-forward) equations.

[3 Marks]

b) A two-input single-output system is governed by the equation $z = ax_1 + bx_2$, where x_1 and x_2 are the inputs; a and b are constant coefficients; and z is the model output. Train a **linear** ANN to find the instrument model using steepest-descent algorithm with learning rate of

0.8. The samples of the inputs, output, and the initial weights are $\begin{bmatrix} 0 & 1 & 2 & 3 \\ 0 & 1 & 2 & 3 \end{bmatrix}^T$, $\begin{bmatrix} 2 & 1 & 3 & 4 \end{bmatrix}^T$, and $\begin{bmatrix} 2 & -1 \end{bmatrix}^T$, respectively.

Train the ANN using:

I) Batch-training algorithm (Calculate for only **two** epochs).

[10 Marks]

II) Online-training algorithm (Calculate for only **one** epoch).

[10 Marks]

—(With Best Wishes)—

Course Examination Committee

Dr. Ahmed Nassef

Remarks: (Answer the following questions... you may use z-transform table given in page 2)

Problem number (1) (10Marks)

- a) For the following discrete-time system (4 Marks)

$$y(n) = x^2(n)$$
 Check whether the system is
 (i) Linear or nonlinear
 (ii) Shift invariant or shift variant

- b) Determine the energy of the following discrete-time signal (6 Marks)

$$x(n) = \begin{cases} \left(\frac{1}{2}\right)^n & n \geq 0 \\ 0 & n < 0 \end{cases}$$

Problem number (2) (10 Marks)

- a) Find z-transform and ROC for the following sequence (5 Marks)

$$x(n) = \begin{cases} 1 & , \text{for } n=0 \text{ and even integers} \\ -1 & , \text{for } n = \text{odd integers} \end{cases}$$
- b) Find the inverse z-transform of (5 Marks)

$$X(z) = \frac{z}{z^2 + 1}$$

Problem number (3) (15 Marks)

- a) Consider the discrete-time sequence $x(n)$, (4 Marks)

$$x(n) = \left\{ \frac{1}{4}, 1, 1, 1, \frac{1}{2}, \frac{1}{2} \right\}$$
 sketch
 (i) $x(n)u(n-2)$
 (ii) $x(-n+1)u(n)$
- b) Determine the range of values 'a' and 'b', for which the LTI system with impulse response (5 Marks)

$$h(n) = \begin{cases} a^n & , n \geq 0 \\ b^n & , n < 0 \end{cases}$$
 is stable.
- c) Determine 4-point DFT of the following sequence (6 Marks)

$$x(n) = \left\{ \frac{1}{4}, 2, 1, 2 \right\}$$

Problem number (4) (15 Marks)

- a) Compute the circular convolution of the following two sequences (5 Marks)

$$x_1(n) = \left\{ \frac{2}{T}, 1, 2, 1 \right\}, \quad x_2(n) = \left\{ \frac{1}{T}, 2, 3, 4 \right\}$$

- b) Obtain the 8-point FFT-DIT of the following sequence (6 Marks)

$$x(n) = \left\{ \frac{1}{T}, 1, 1, 1, 0, 1, 1, 1 \right\}$$

using radix-2 algorithm. Follow exactly the corresponding signal flow graph and keep track of all the intermediate quantities by putting them on the diagram.

- c) Given the following transfer function, (4 Marks)

$$H(z) = \frac{0.5(z^2 - 1)}{z^2 + 1.3z + 0.36}$$

Draw

- (i) Direct form-I structure.
- (ii) Parallel form structure via first order sections.

Problem number (5) (20 Marks)

- a) Design an analog lowpass Butterworth filter with an acceptable passband attenuation of -2 dB at 20 radians/second. The attenuation in the stopband should be more than 10 dB beyond 30 radians/second. (10 Marks)

- b) Design a highpass Butterworth filter of second order and cutoff frequency of 50 Hz, then find the corresponding digital filter using bilinear transformation with sampling period $T=0.01$ second. (10 Marks)

GOOD LUCK

$x(n)$	$X(z)$
$\delta(n)$	1
$u(n)$	$\frac{z}{z-1}$
a^n	$\frac{z}{z-a}$
$\sin \omega n$	$\frac{z \sin \omega}{z^2 - 2z \cos \omega + 1}$
$\cos \omega n$	$\frac{z(z - \sin \omega)}{z^2 - 2z \cos \omega + 1}$

Dr. Ali Tahoun

TANTA UNIVERSITY
FACULTY OF ENGINEERING



Department : Computer and Control Engineering

Lecturer : Professor Ahmed F. Amer

Subject : Digital Control Engineering

Date : 21 / 1 / 2010

Marks : 85

Time : 3 Hrs

Final Exam

Answer Four Questions:

1. The schematic diagram of a servomechanism is given in the figure shown below. The system constants are as follows:

Synchro sensitivity, K_s = 1 volt/deg.

Amplifier gain, K_A = 20 volt/volt

Motor torque constant, K_c = 10^{-5} N.m/volt

Load inertia, J_L = 1.5×10^{-5} g.m²

Viscous friction, f_L = 1×10^{-5} Nm/rad/sec

Tachometer const., K_t = 0.2 volt/rad/sec

Motor inertia and friction are assumed to be negligible.

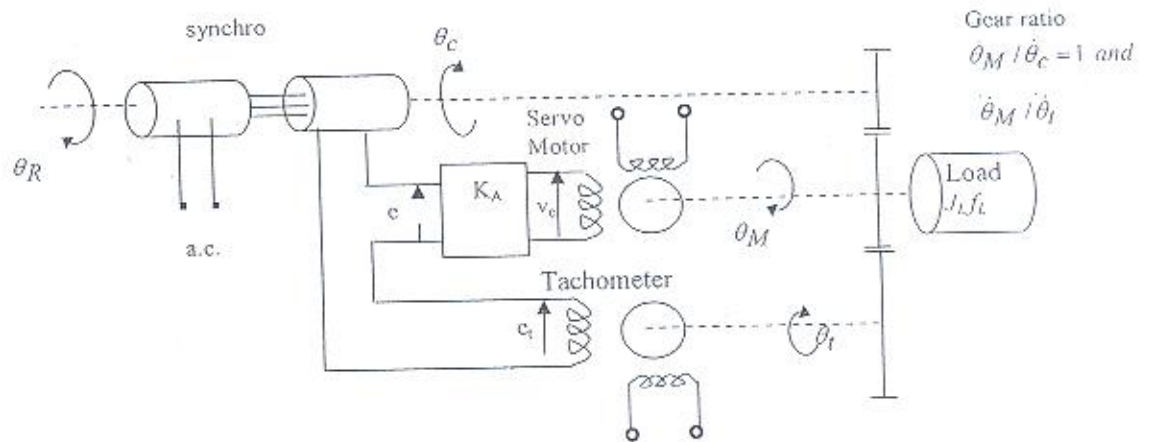

Fig. 2

- Find the value of ξ assuming that the tachometer is disconnected. Determine also the steady-state error corresponding to an input velocity of 1 rad/sec.
- Determine ξ when the tachometer is included as part of the system.
- The tachometer is now removed and the amplifier is replaced by a proportional Plus integral amplifier whose output voltage is given by $V_o = K_A e + K_A \int e dt$, compare the steady-state behavior of the system with that of, part (a).

2. a) The block diagram of a servomechanism is shown in figure below. Determine the value of system gain K and tachometer gain K_t so that the maximum overshoot to a unit step response is 40 percent and peak time is 0.8 second.

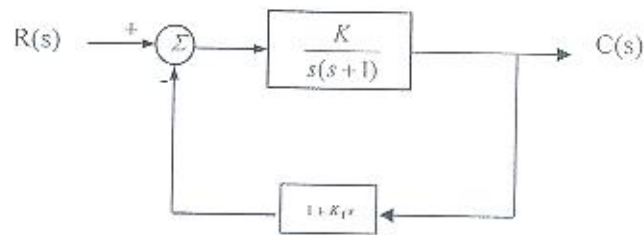

Fig.4

- b) Consider a unity feedback system having an open-loop transfer function :

$$G(j\omega) = \frac{K}{j\omega(1 + j0.2\omega)(1 + j0.5\omega)}$$

By the use of Nyquist stability criterion on the direct polar plot, determine:

- The gain margin "GM" and phase margin "PM" for $K=1$.
 - The open-loop gain for a gain margin of 20 db.
 - The open-loop gain for a phase margin of 45° .
3. Draw a rough sketch for the root locus plot of a unity feedback system with an open-loop transfer function:

$$G(s) = \frac{K}{s(s+2)(s+5)}$$

- find the range for values of K for which the system has damped oscillatory response.
 - What is the greatest value of K which can be used before continuous oscillations occur.
 - Determine the frequency of continuous oscillations.
 - Find the value of K so that the dominant pair of complex poles of the system has a damping ratio of 0.5.
4. Draw Bode diagrams for the system with transfer function :

$$G(s) = \frac{1000(s+2)}{s(s+5)(s^2 + 6s + 10)}$$

Find the gain margin and phase margin.

5. The figure represents a plot for the log magnitude curve of a forward transfer function $G(j\omega)$ of a unity feedback system (the drawing is not to scale):
- Find the system transfer function $G(s)$
 - Find the gain margin and phase margin.
 - Is the closed loop system stable?
 - If an amplifier of gain K is added in cascade with the forward transfer function found above, find the limiting value of K for a stable operation of the system.

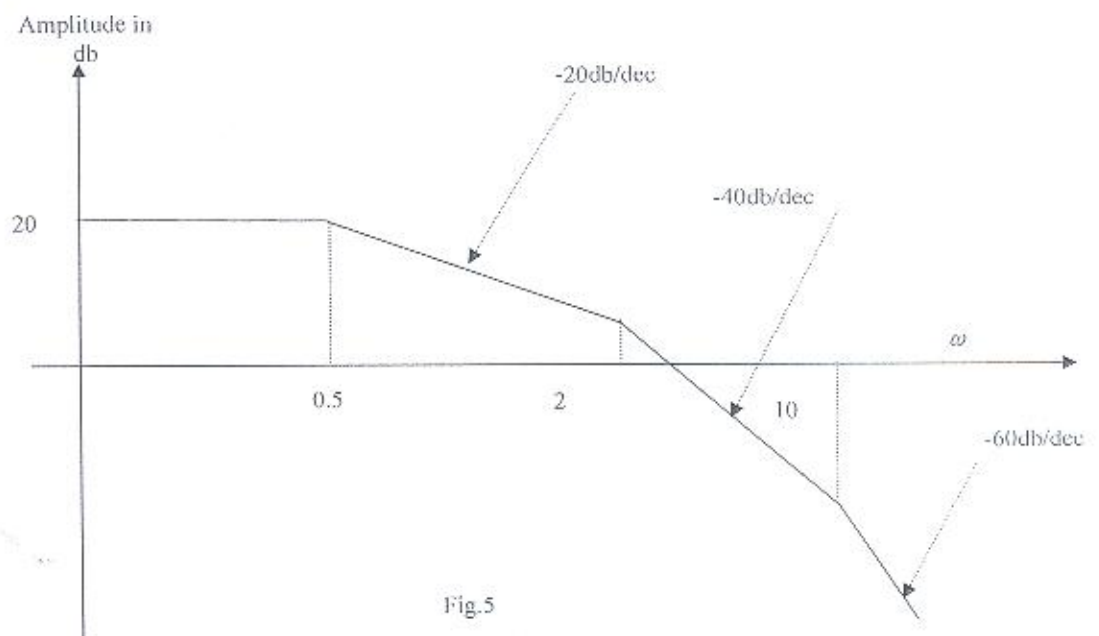

6. Consider a unity feedback system with an open-loop transfer function of,

$$G(s) = \frac{K}{s(s+1)(s+4)}$$

The system is to be compensated according to the following design specifications :

Damping ratio, $\zeta = 0.5$.

Natural frequency, $\omega_n = 2$ rad/sec.

Design a suitable compensator for this system such that it achieves the above design requirements .

TANTA UNIVERSITY
FACULTY OF ENGINEERING



Department : Computer and Control Engineering

Lecturer : Professor Ahmed F. Amer

Subject : Digital Control Engineering

Date : 21 / 1 / 2010

Marks : 85

Time : 3 Hrs

Final Exam

Answer Four Questions:

1. The schematic diagram of a servomechanism is given in the figure shown below. The system constants are as follows:

Synchro sensitivity, K_s = 1 volt/deg.

Amplifier gain, K_A = 20 volt/volt

Motor torque constant, K_e = 10^{-5} N.m/volt

Load inertia, J_L = 1.5×10^{-5} g.m²

Viscous friction, f_l = 1×10^{-5} Nm/rad/sec

Tachometer const., K_t = 0.2 volt/rad/sec

Motor inertia and friction are assumed to be negligible.

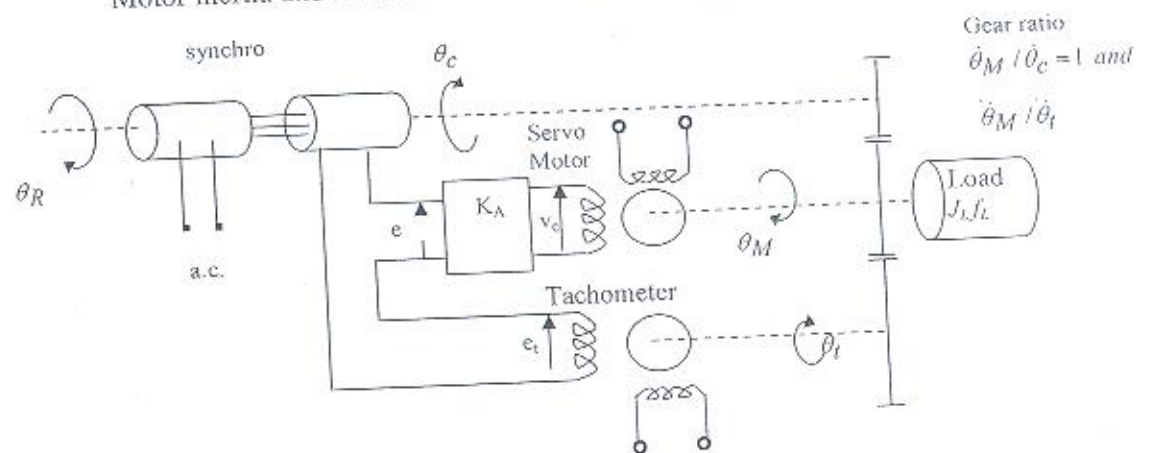

Fig. 2

- Find the value of ξ assuming that the tachometer is disconnected. Determine also the steady-state error corresponding to an input velocity of 1 rad/sec.
- Determine ξ when the tachometer is included as part of the system.
- The tachometer is now removed and the amplifier is replaced by a proportional Plus integral amplifier whose output voltage is given by $V_o = K_A e + K_A \int e dt$, compare the steady-state behavior of the system with that of, part (a).

2. a) The block diagram of a servomechanism is shown in figure below. Determine the value of system gain K and tachometer gain K_t so that the maximum overshoot to a unit step response is 40 percent and peak time is 0.8 second.

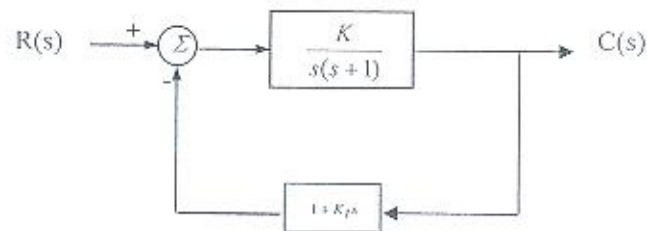

Fig.4

- b) Consider a unity feedback system having an open-loop transfer function :

$$G(j\omega) = \frac{K}{j\omega(1 + j0.2\omega)(1 + j0.5\omega)}$$

By the use of Nyquist stability criterion on the direct polar plot, determine:

- The gain margin "GM" and phase margin "PM" for $K=1$.
 - The open-loop gain for a gain margin of 20 db.
 - The open-loop gain for a phase margin of 45° .
3. Draw a rough sketch for the root locus plot of a unity feedback system with an open-loop transfer function:

$$G(s) = \frac{K}{s(s+2)(s+5)}$$

- find the range for values of K for which the system has damped oscillatory response.
 - What is the greatest value of K which can be used before continuous oscillations occur.
 - Determine the frequency of continuous oscillations.
 - Find the value of K so that the dominant pair of complex poles of the system has a damping ratio of 0.5.
4. Draw Bode diagrams for the system with transfer function :

$$G(s) = \frac{1000(s+2)}{s(s+5)(s^2+6s+10)}$$

Find the gain margin and phase margin.

5. The figure represents a plot for the log magnitude curve of a forward transfer function $G(j\omega)$ of a unity feedback system (the drawing is not to scale):
- Find the system transfer function $G(s)$
 - Find the gain margin and phase margin.
 - Is the closed loop system stable?
 - If an amplifier of gain K is added in cascade with the forward transfer function found above, find the limiting value of K for a stable operation of the system.

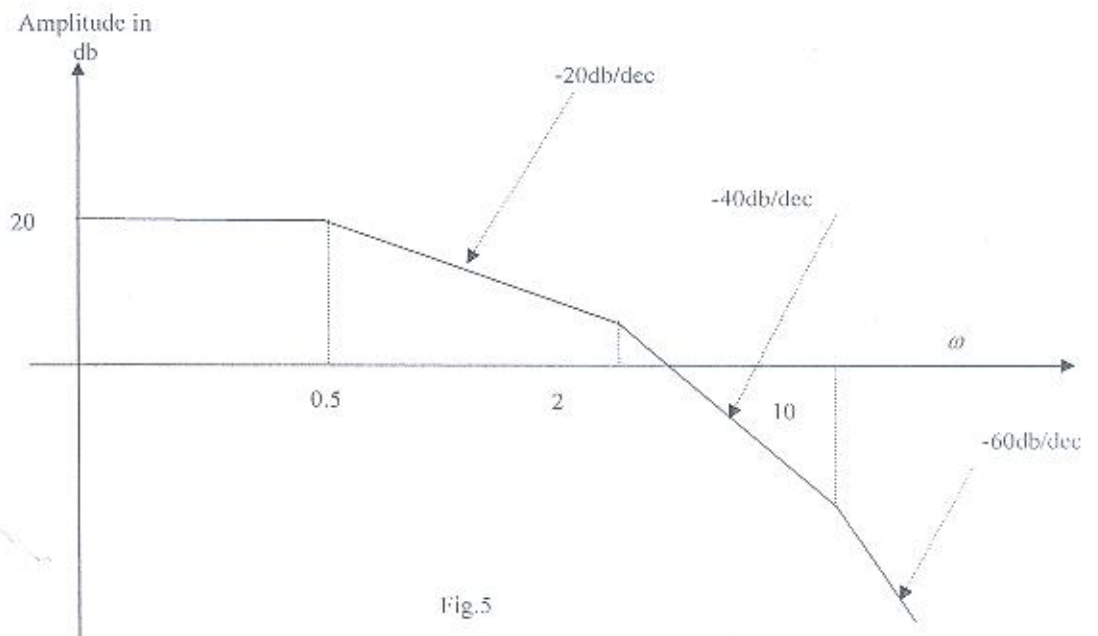

6. Consider a unity feedback system with an open-loop transfer function of,

$$G(s) = \frac{K}{s(s+1)(s+4)}$$

The system is to be compensated according to the following design specifications :

Damping ratio, $\zeta = 0.5$.

Natural frequency, $\omega_n = 2$ rad/sec.

Design a suitable compensator for this system such that it achieves the above design requirements .

Course Title: **Stochastic Processes** العمليات العشوائية ثلاثة حاسبات
Date: 4.2.2010 (First term)Course Code: CCE3117 3rd year
Allowed time: 3 hrs No. of Pages: (2)Answer all the following questions:**Question No. 1**

(17 marks)

(a) If A and B are independent events, prove that A and B^c are independent.(b) Let A and B be events with $P(A) = 1/3$, $P(B) = 1/2$ and $P(A \cap B) = 1/4$.Find : i- $P(A|B)$, ii- $P(B|A)$, iii- $P(A \cup B)$, iv- $P(A^c|B^c)$, v- $P(B^c|A^c)$

(c) If X be a continuous random variable with the probability

$$P(x) = x/4 \quad 0 < x < 4, \text{ and zero elsewhere}$$

Find the **cumulative** distribution function, mean, variance, and standard deviation of X.(d) Given a and b are constants, find with prove i - $E(a) = ?$ ii - $\text{Var}(aX + b) = ?$

where X is a continuous random variable.

Question No. 2

(17 marks)

(a) Three light bulbs are chosen at random from 20 bulbs of which 5 are defective. Find the probability that : i- exactly one is defective, ii- none is defective,

iii- at least one is defective iv- at most one is defective.

(b) Let X be a continuous random variable with distribution

$$f(x) = x/4 + k \quad \text{if } 0 \leq x \leq 4 \text{ and } f(x) \text{ equals zero elsewhere.}$$

Sketch the graph of $f(x)$ and thus i- Evaluate k ii- Find $P(1 \leq X \leq 2)$

(c) A pair of fair dice is tossed. Let X assigns to the sum of dices numbers. Calculate the mean, variance and standard deviation of X.

(d) Let X be a random variable with the binomial distribution $b(k;n,p)$.Prove that $E(X) = np$.**Question No. 3**

(18 marks)

(a) A fair die is tossed. Let X denotes twice the number appearing, and let Y denote 1 or 4 according as an odd or an even number appears. Find the probability, expectation, variance and standard deviation of:

i- X ii- Y iii- $X+Y$ iv- XY

- (b) A coin weighted so that $P(H) = 1/3$ and $P(T) = 2/3$ is tossed until a head or four tails occur. Find the expected number of tosses of the coin.
- (c) Determine the expected number of boys in a family with 8 children, assuming the sex distribution to be equally probable. What is the probability that the expected number of boys does occur?
- (d) Let X be a random variable with the binomial distribution $b(k;n,p)$. Prove that $E(X) = np$.

Question No. 4

(18 marks)

- (a) Determine the expected number of boys in a family with 8 children, assuming the sex distribution to be equally probable. What is the probability that the expected number of boys does occur?
- (b) Suppose the diameters of bolts manufactured by a company are normally distributed with mean 0.25 inches and standard deviation 0.02 inches. A bolt is considered defective if its diameter is ≤ 0.20 inches or ≥ 0.28 inches. Find the percentage of defective bolts manufactured by the company.
- (b) Suppose the heights of 1000 male students are normally distributed with mean 175 centimeters and standard deviation 20 centimeters. Find the number of students with heights:
- i- less than or equal to 130 centimeters,
 - ii- between 150 and 160 centimeters,
 - iii- between 170 and 180 centimeters
 - iv- greater than or equal to 200 centimeters.

Best wishes

Dr. Eng. Alayed Sallam

جامعة طنطا
كلية الهندسة

التاريخ: ٢٠١٠/ ٢/ ٤
الزمن: ٢ ساعة

المادة: تنظيم صناعي
الفرقة: ٣ قديم/ حاسبات

أجب على خمسة من الأسئلة التالية:

- ١- ماهي العوامل التي تؤثر على تكلفة الإستثمار وتكلفة الإنتاج ، وماهي نقطة التعادل وأهمية تحديدها مع التوضيح بالرسم؟
- ٢- ماهي الأهداف التي تسعى السلامة الصناعية إلى تحقيقها في المنشآت الصناعية، وما هي الشروط الواجب قبل تشغيل الآلة؟
- ٣- ماكينة تكلفة شرائها ٦٠٠٠٠ دولار ، وتكلفة تركيبها ٤٠٠٠٠ دولار وعمرها النافع مقدر بخمسة سنوات ، وقيمة النفاية (الانقراض) لها في نهاية السنة الخامسة هو صفر ، احسب ما يلي:
 - القسط السنوي للاهلاك باستخدام طريقة الإنحدار في حساب الإهلاك ، مع تقدير تكلفة المعدة في نهاية السنة الثانية من عمرها النافع.
 - القسط السنوي للاهلاك باستخدام طريقة الإنحار المتضاعف في حساب الإهلاك، مع تقدير تكلفة المعدة في نهاية عمرها النافع.
- ٤- ماهو تعريفك للإنتاجية وما هي أنواعها المختلفة.
احسب مؤشر الإنتاجية المتعدد لعدد ١٠٠٠ وحدة إنتاجية بقيمة إجمالية مقدارها ١٥٠٠٠٠ دولار ، وتبلغ تكلفة العمالة ٧٠٠٠ دولار ، والمواد الخام ٨٠٠٠ دولار.
- ٥- يعتمد تحليل الوضع للمنشآت الصناعية على دراسة وتحليل البيئة الداخلية والبيئة الخارجية للمنشأة ، فما هي الطرق أو الوسائل المختلفة التي يمكن إستخدامها في تحليل الوضع مع الشرح بإيجاز لكل منها؟
- ٦- هناك خطوات ومراحل متتابعة يجب العمل بها عند إستخدام طريقة التسويق ، فما هي تلك الخطوات او المراحل ، مع الشرح بإيجاز لكل مرحلة منها.

Answer the following *four* questions. Time allowed : 3 hours.

Question 1 (22 Marks)

- What is relational algebra? Discuss three of its main operators.
- Show, through an illustrative example, that the natural join can be simulated using renaming, equi-joining, and projection.
- Consider a relation EMPLOYEES given as :

EMPLOYEES			
RegNum	Name	Age	Salary
201	Mona Hamdy	34	40
203	Mona Fawzy	23	35
204	Amr Khalil	38	61
205	Ihab Zohdy	44	38
310	Medhat Aly	49	60
331	Samir El-Khouly	50	60
352	Ihab Zohdy	44	70
401	Samir Nassar	34	70
475	Mona Hamdy	50	65

where the attribute Salary gives the employee's salary per year in thousands of Egyptian pounds. Show that :

- $$\begin{aligned} & \sigma_{Age > 40 \wedge Salary < 60} (EMPLOYEES) \\ &= \sigma_{Age > 40} (\sigma_{Salary < 60} (EMPLOYEES)) \\ &= \sigma_{Age > 40} (EMPLOYEES) \cap \sigma_{Salary < 60} (EMPLOYEES) \end{aligned}$$
- $$\begin{aligned} & \sigma_{Age > 40 \wedge \neg (Salary < 60)} (EMPLOYEES) \\ &= \sigma_{Age > 40} (EMPLOYEES) - \sigma_{Salary < 60} (EMPLOYEES) \end{aligned}$$

Question 2 (22 Marks)

Consider the relation EMPLOYEES of Ques.1, part(c), and a relation SUPERVISORS given as :

SUPERVISORS	
Head	Employee
310	201
310	203
310	204
331	205
401	310
401	331
475	352

Determine the final result of each of the following expressions, indicating the results of the intermediate steps :

- (a) π RegNum, Name, Age (σ Salary > 40 (EMPLOYEES))
- (b) π Head (SUPERVISORS \bowtie _{Employee = RegNum} (σ Salary > 40 (EMPLOYEES))))
- (c) π NameS, SalaryS (ρ RegNumS, NameS, AgeS, SalaryS \leftarrow RegNum, Name, Age, Salary (EMPLOYEES) \bowtie _{RegNumS = Head (SUPERVISORS \bowtie _{Employee = RegNum} (σ Salary > 40 (EMPLOYEES))))}

Question 3 (23 Marks)

Consider the two relations EMPLOYEES and SUPERVISORS of Ques.2. Write a relational-algebra expression and determine the final result for each of the following queries :

- Find the employees earning more than their respective supervisors, indicating registration numbers, names, and salaries of the employees and supervisors.
- Find the registration numbers and names of the supervisors whose employees all earn more than 40 thousand.
- Find the registration numbers and names of the supervisors whose employees all earn less than 40 thousand.

Question 4 (23 Marks)

- What does the acronym SQL stand for ?
- Discuss four of the elementary-domain families provided by SQL .
- Consider the relation EMPLOYEES of Ques.1, part(c). Write SQL instructions for the following queries, indicating the final result in each case :
 - Find the names of the employees whose age exceeds 45 years.
 - Find the registration numbers and salaries of the employees whose age is less than 45 years. Rename the attribute Salary as Income.
 - Find the registration numbers and names of the employees whose age exceeds 45 years and whose salary is less than 40 thousand.
 - Find the registration numbers and names of the employees whose age exceeds 45 years or whose salary is less than 40 thousand.
 - Find all information relating to the employees whose names have a 'y' as the last letter.

Prof. Dr. Mahmoud M. Fahmy